

LFC Series

Recirculating Fume Cabinet



Description

The LFC Series fume cabinet is a compact, recirculating fume cabinet that has been designed to provide operator safety and ease of use in laboratory applications. Capture of fumes is achieved by inward airflow at a velocity of > 0.5 m/s and carbon filtration of exhaust air.

The upper housing contains the mains switch, low-airflow alarm, speed control and carbon filter.



The upper housing

Optional open-base work area



Application

Cabinets are supplied with an open base and can be positioned over an existing utility such as a sink or be placed directly on to a flat bench. The LFC cabinets are available in three widths; 600mm (LFC60), 900mm (LFC90) and 1200mm (LFC120).

An optional work tray, manufactured from stainless steel, is available if containment of spills is required. A trolley stand is also available as an option across the LFC cabinet range.

The standard activated-carbon filter is suitable for use with a wide range of common laboratory fumes. Special-purpose carbon filters for specific applications are available to order.



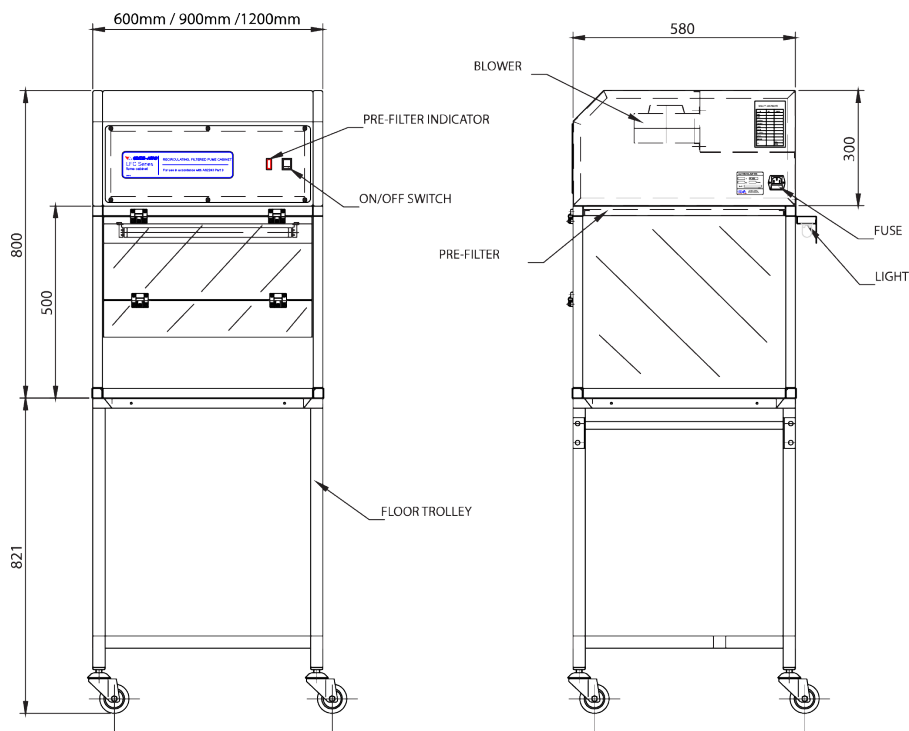

Specifications

Construction	Powdercoated, galvanised steel top module
Colour	Grey
Windows	Clear Perspex
Spillage Tray	Optional stainless or polypropylene tray
Fan	Centrifugal
Electrical Supply	240V, 50Hz
Controls	Mains Power On/Off
Monitoring	Alarm for airflow and filter condition.
Airflow m³/h	200
Face Velocity m/s	> 0.5
Carbon filter no. & mass LFC60	1 x 4kg
Carbon filter no. & mass LFC90 & LFC120	2 x 4kg
Noise Level dB(A)	58

Dimensions

MODEL	LFC60	LFC90	LFC120
WIDTH	600 mm	900 mm	1200 mm
DEPTH	580 mm	580 mm	580 mm
OVERALL HEIGHT	800 mm	800 mm	800 mm
WORKING HEIGHT	500 mm	500 mm	500 mm
WORK AREA	580 x 520 mm	580 x 820 mm	580 x 1120 mm

On-Site Testing

LFC cabinets are factory tested and certified by a NATA-Accredited laboratory. Additional testing and certification is recommended as follows:

- On site prior to use
- After maintenance
- After filter replacement
- After re-location
- At least annually
- In special circumstances, e.g. if faulty operation is suspected.



AES Environmental maintains an ISO 9001 quality management system to ensure process and product conformance.

Important note:

Specifiers and intending users should see AS2243.9, Clause 1.2 which sets out the intended applications and limitations of these cabinets.

The Company

AES Environmental is an Australian owned manufacturing business producing products under Clyde-Apac, Email Air Handling and Vokes brand names for industries that are as varied as industrial plants, commercial buildings, power stations, food processing, healthcare, science and electronics. AES Environmental considers the Australian Standards as a core component of its product mix and has developed an export market in 25 countries, promoting Australian Standards, engineering and manufacturing solutions. AES Environmental, a trusted manufacturer capable of delivering reliable product solutions to highly-critical applications, where the control of hazardous airborne contamination is often critical to process and personnel.

© 2022 AES Environmental | Bulletin No. 05J.07.17 AES135 REV4

In keeping with our policy of continuing product improvement, we reserve the right to alter specifications without notice.



9A Pembury Rd, Minto 2566
Ph 1300 550 116 F 1300 550 117
sales@aesenvironmental.com.au
www.aesenvironmental.com.au

